

Wirefree Tubular Motors

RTM5VL25, RTM5VL28, RTM5VL35

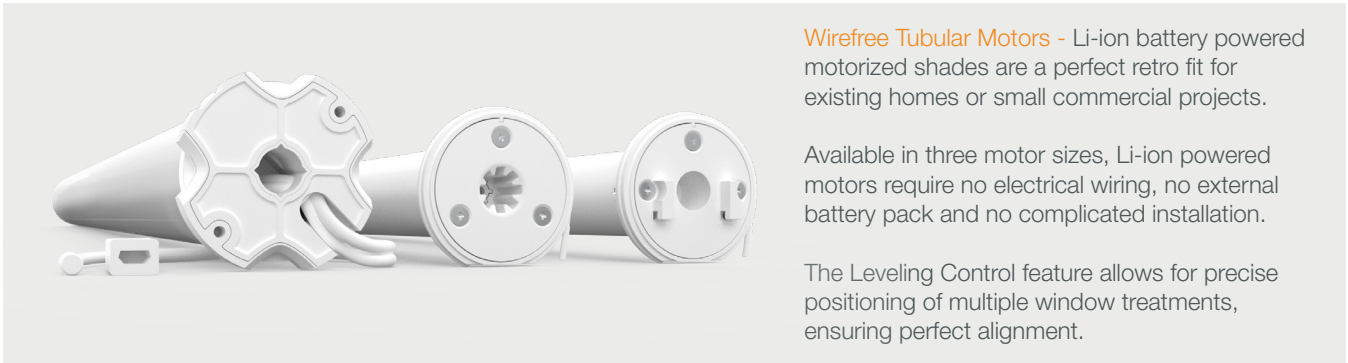

Wirefree Tubular Motors - Li-ion battery powered motorized shades are a perfect retro fit for existing homes or small commercial projects.

Available in three motor sizes, Li-ion powered motors require no electrical wiring, no external battery pack and no complicated installation.

The Leveling Control feature allows for precise positioning of multiple window treatments, ensuring perfect alignment.

FEATURES



2-Way RF Communication



Adjustable Speed

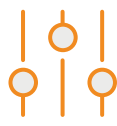

Leveling Control

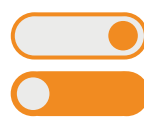

Preferred Upper / Lower Limit Settings



Favorite Position

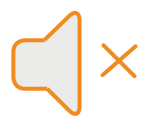

Quiet Operation



PACK CONTENTS

- Wirefree Tubular Motor
- Instruction Manual

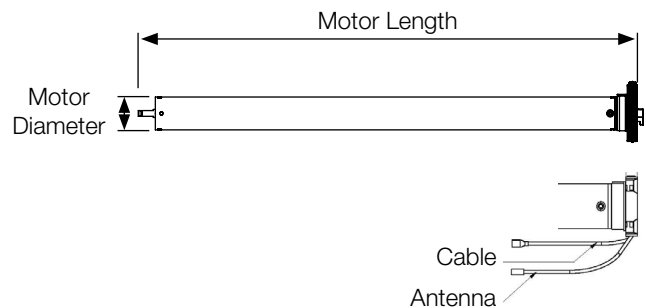
	Motor Size	Motor Length	Motor Dia.	Cable / Antenna
RTM5VL25S	25 mm	18 7/8"	1"	-
RTM5VL25	25 mm	21 3/4"	1"	-
RTM5VL28	28 mm	25 9/16"	1 1/8"	-
RTM5VL35	35 mm	33 1/2"	1 3/8"	7 1/16" 6 5/16"



INSTALLATION

 Installation Instructions:
 

25 mm or 28 mm

35 mm

SAFETY INSTRUCTIONS

WARNING: Important safety instructions to be read before installation.

Incorrect installation can lead to serious injury and will void manufacturer's liability and warranty.

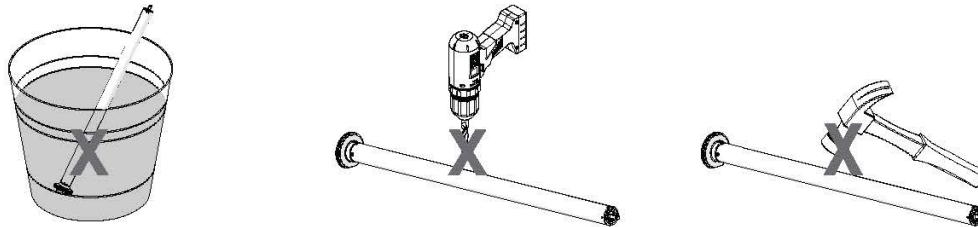

WARNING: Important safety instructions to be read before installation and use.

Incorrect installation or use can lead to serious injury and will void manufacturer's liability and warranty. It is important for the safety of persons to follow the enclosed instructions. Save these instructions for future reference.

- Do not expose to water, moisture, humid and damp environments or extreme temperatures.
- Persons (including children) with reduced physical, sensory or mental capabilities, or lack of experience and knowledge should not be allowed to use this product.
- Use or modification outside the scope of this instruction manual will void warranty.
- Installation and programming to be performed by a suitably qualified installer.
- Follow installation instructions.
- For use with motorized shading devices.
- Keep away from children.
- Frequently inspect for improper operation. Do not use if repair or adjustment is necessary.
- Keep clear when in operation.
- Replace battery with correctly specified type.

COMPLIANCE STATEMENT

This device complies with Part 15 of the FCC Rules / Industry Canada licence-exempt RSS standard(s). Operation is subject to the following two conditions:

- (1) this device may not cause harmful interference, and
- (2) this device must accept any interference received, including interference that may cause undesired operation.

Le présent appareil est conforme aux CNR d'Industrie Canada applicables aux appareils radio exempts de licence. L'exploitation est autorisée aux deux conditions suivantes:

- (1) l'appareil ne doit pas produire de brouillage, et
- (2) l'utilisateur de l'appareil doit accepter tout brouillage radioélectrique subi, même si le brouillage est susceptible d'en compromettre le fonctionnement.

Changes or modifications not expressly approved by the party responsible for compliance could void the user's authority to operate the equipment.

This equipment has been tested and found to comply with the limits for a Class B digital device, pursuant to part 15 of the FCC Rules. These limits are designed to provide reasonable protection against harmful interference in a residential installation.

This equipment generates uses and can radiate radio frequency energy and, if not installed and used in accordance with the instructions, may cause harmful interference to radio communications. However, there is no guarantee that interference will not occur in a particular installation.

If this equipment does cause harmful interference to radio or television reception, which can be determined by turning the equipment off and on, the user is encouraged to try to correct the interference by one or more of the following measures:

- Reorient or relocate the receiving antenna.
- Increase the separation between the equipment and receiver.
- Connect the equipment into an outlet on a circuit different from that to which the receiver is connected.
- Consult the dealer or an experienced radio/TV technician for help.

To satisfy FCC / IC RF exposure requirements, a separation distance of 20 cm or more should be maintained between the antenna of this device and persons during device operation.

To ensure compliance, operations at closer than this distance is not recommended.

Les antennes installées doivent être situées de façon à ce que la population ne puisse y être exposée à une distance de moins de 20 cm. Installer les antennes de façon à ce que le personnel ne puisse approcher à 20 cm ou moins de la position centrale de l'antenne.

La FCC des états-unis stipule que cet appareil doit être en tout temps éloigné d'au moins 20 cm des personnes pendant son fonctionnement.



Do not dispose of in general waste.
Please recycle batteries and damaged electrical products appropriately.



CONTENTS

1 ASSEMBLY	4	8 FAVORITE POSITIONING	11
2 RETROFIT INSTALLATION	5	8.1 Set a favorite position	11
3 CHARGING	5	8.2 Send shade to favorite position	11
4 P1 BUTTON FUNCTIONS	6	8.3 Delete favorite position	11
4.1 Motor state test	6	9 TILT & ROLLER MODE	12
4.2 Motor configuration options	6	9.1 Toggle motor to Tilt Mode	12
5 INITIAL SET-UP	7	9.2 Toggle motor to Roller Mode	12
5.1 Pair motor with controller	7	10 ADJUSTING SPEED	13
5.2 Check motor direction	7	10.1 Increase motor speed	13
5.3 Set limits	8	10.2 Decrease motor speed	13
6 ADJUSTING LIMITS	9	11 SOFT STOP CONFIGURATION	14
6.1 Adjust upper limit	9	11.1 Turn Soft Stop OFF	14
6.2 Adjust lower limit	9	11.2 Turn Soft Stop ON	14
7 CONTROLLERS AND CHANNELS	10	12 BATTERY CHECK FUNCTION	15
7.1 Using P2 button on existing controller to add a new controller or channel	10	12.1 Send Shade to battery charge level	15
7.2 Using a pre-existing controller to delete a controller or channel	10	13 CHARGING LED	15
		13.1 Turn Charging LED ON/OFF	15
		13 SLEEP MODE	16
		13 TROUBLE SHOOTING	16

PRODUCT SPECIFICATIONS

Parameters	Value for 25 mm	Value for 28 mm	Value for 35 mm
Voltage	5 V DC		
Torque	1.1 Nm	2.0 Nm	3.0 Nm
Max. Run Time	12 min.		
Speed	20 RPM (Adj. to 24 or 28)	28 RPM (Adj. to 24 or 20)	28 RPM (Adj. to 24 or 20)
Radio Frequency	433.92 MHz		
Amps	0.83 A	1.25 A	2.2 A
Sound Level	~46 DB	~44 DB	~53 DB
Limit Switch Type	Electronic		
Temperature Working Range	32° F - 140° F (0° C - 60° C)		

1 ASSEMBLY

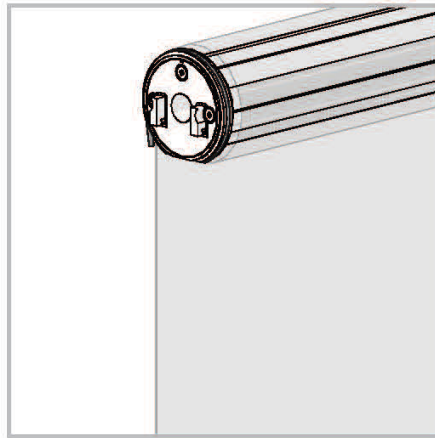
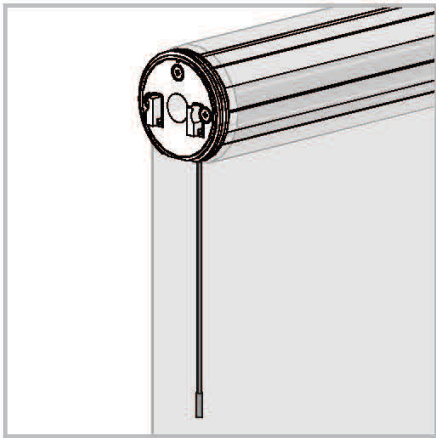
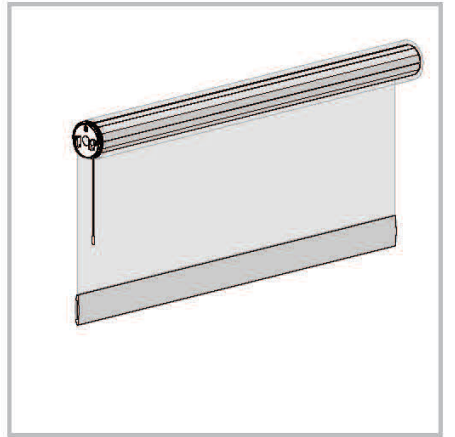
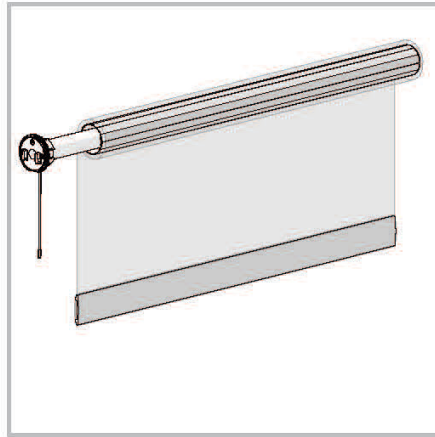
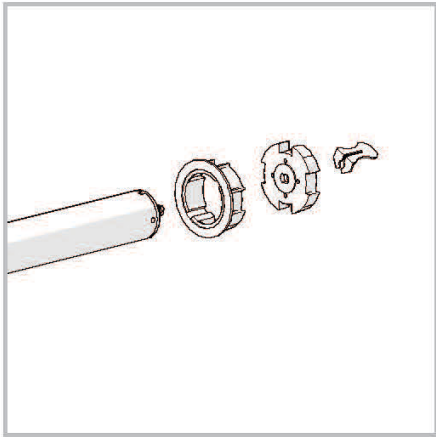
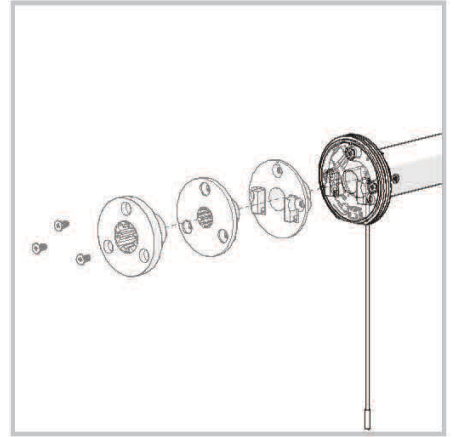
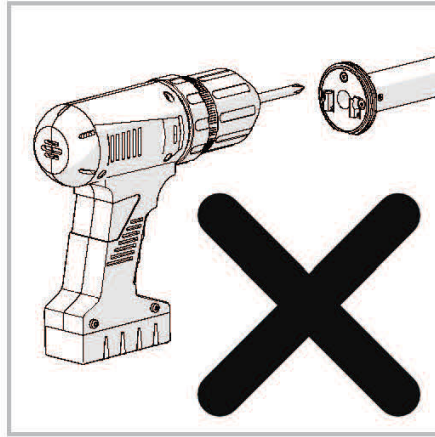
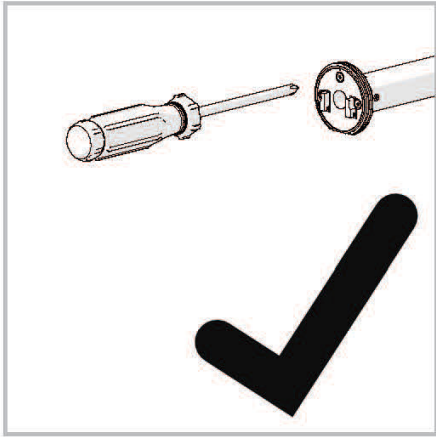

2 RETROFIT INSTALLATION

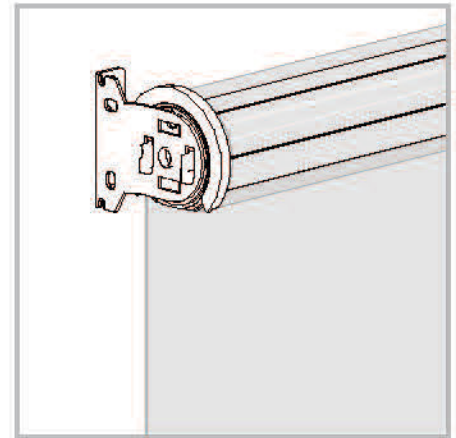
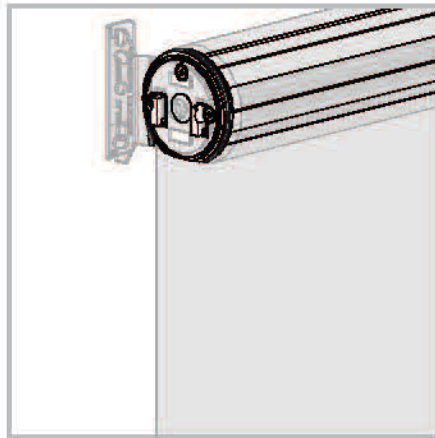
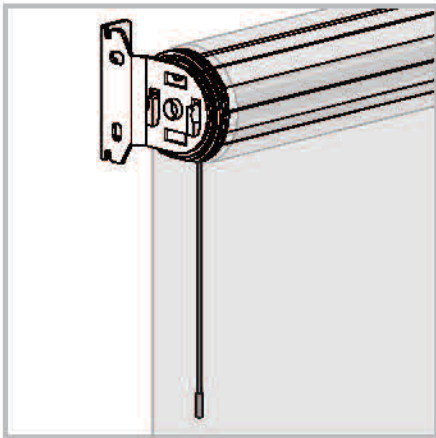
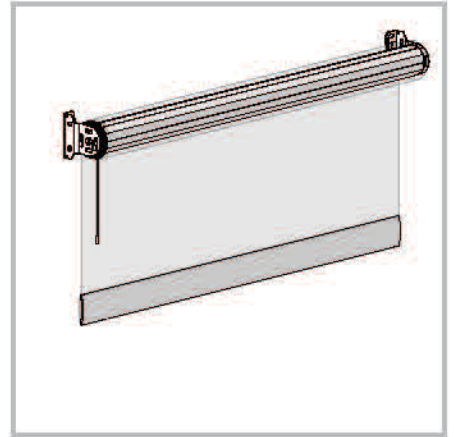
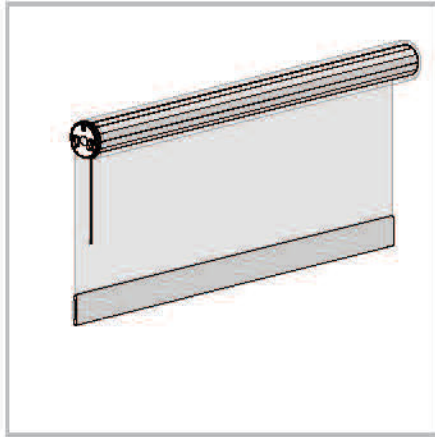
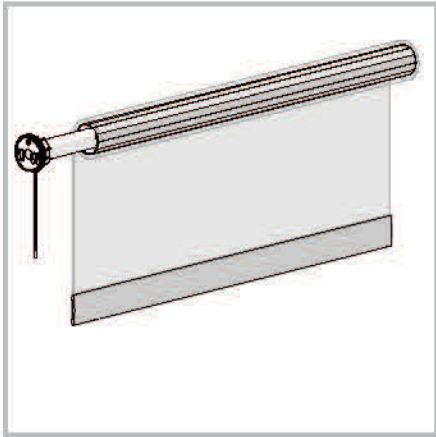
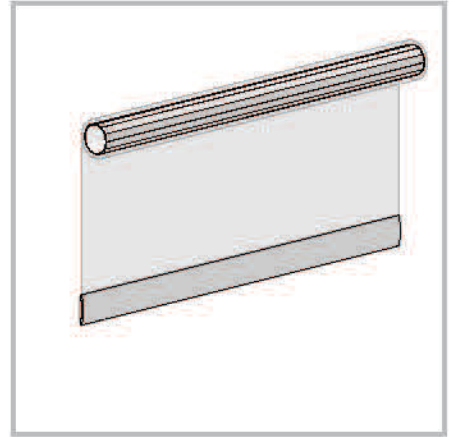
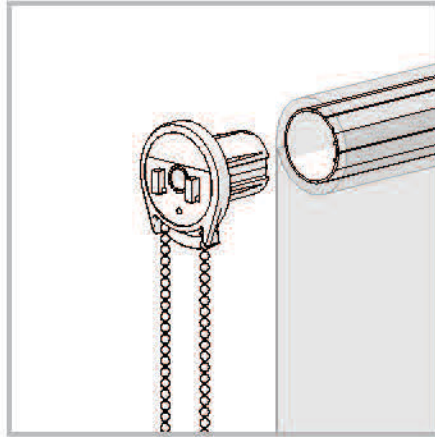
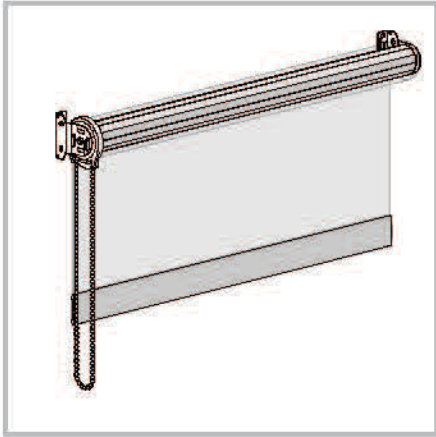

3 CHARGING

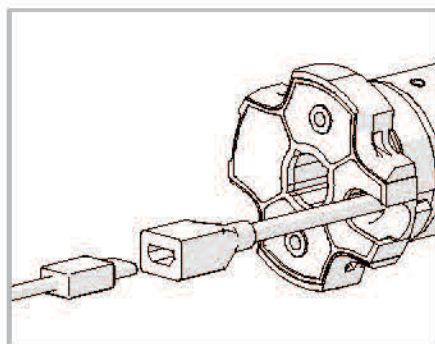
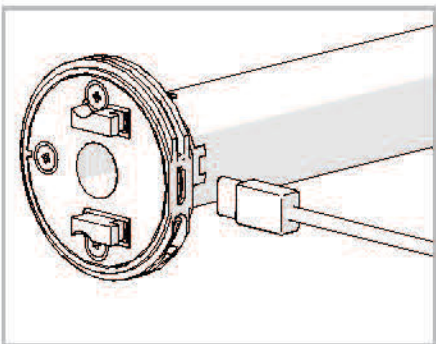

4 P1 BUTTON FUNCTIONS

4.1 Motor state test

This table describes the function of a short P1 Button press/release (<2 seconds) depending on current motor configuration.

P1 Press	Condition	Function Achieved	Visual Feedback	Audible Feedback	Function Described
Short Press	If limit is NOT set	None	No Action	None	No Action
	If limits are set	Operational control of motor, run to limit. Stop if running	Motor Runs	None	Operational control of motor after pairing and limit setting is completed first time
	If motor is in "Sleep Mode" & limits are set	Wake and control	Motor wakes and runs in a direction	None	Motor is restored from Sleep Mode and RF control is active

4.2 Motor configuration options

The P1 Button is utilized to administer motor configurations as described below.

Hold P1 button on motor head.

Activate Pairing Mode



Sleep Mode



Reverse Direction

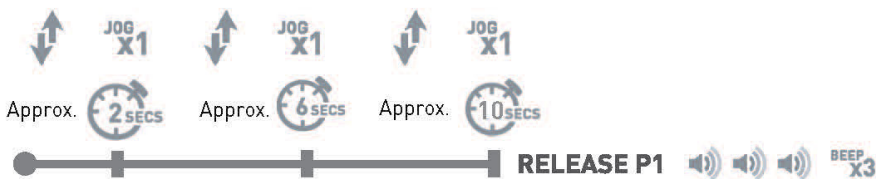

Reset To Factory Settings

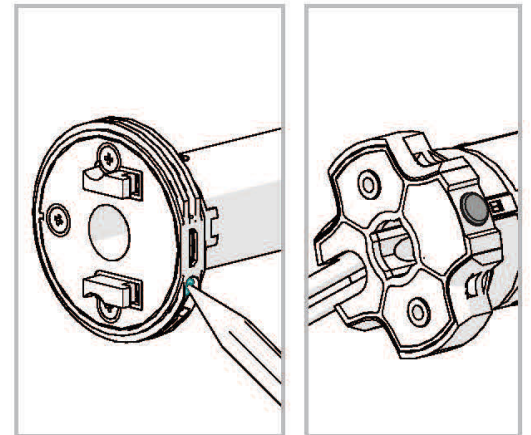

P1 button on motor head.

5 INITIAL SET UP

5.1 Pair motor with controller

Select channel on controller.



Hold **P1** button on motor head.

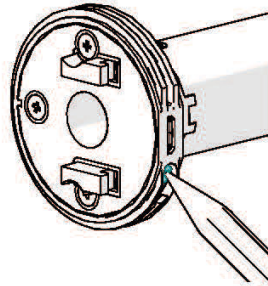

Hold **STOP** on controller.



IMPORTANT

Consult user manual for your controller for information on selecting channel.

Motor Response



Motor Response



 **Motor is now in step mode and ready for setting limits**

5.2 Check motor direction

To check travel direction of shade, press **UP** or **DOWN** on controller..



To reverse shade direction, hold both **UP** and **DOWN**.

Until the motor responds.



Quick Press = Step
Long Press = Continuous Travel

Motor Response



IMPORTANT

Damage to shade may occur when operating motor prior to setting limits. Attention should be given.

IMPORTANT

Reversing motor direction using this method is only possible during initial set-up

5.3 Set Limits

IMPORTANT

Cycle shade up and down prior to setting limits to settle fabric

Move shade to the desired highest or lowest position by pressing the **UP** or **DOWN** buttons on controller.



To save upper limit, hold **UP** and **STOP**.



Motor Response



Move shade to the desired highest or lowest position by pressing the **UP** or **DOWN** buttons on controller.



To save lower limit, hold **DOWN** and **STOP**.



Motor Response



IMPORTANT

After setting limits, motor will automatically exit from initial set-up mode.

6 ADJUSTING LIMITS

6.1 Adjust upper limit

Hold **UP** and **STOP** on controller.



Move shade to the desired highest position by pressing the **UP** or **DOWN** button.

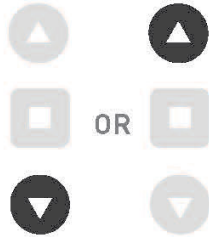

To save upper limit, hold **UP** and **STOP**.



Motor Response



Motor Response



6.2 Adjust lower limit

Hold **DOWN** and **STOP** on controller.



Move shade to the desired lowest position by pressing the **UP** or **DOWN** button.



To save lower limit, hold **DOWN** and **STOP**.



Motor Response



Motor Response



IMPORTANT

The bottom limit should be set ~ 1.38 in. (35mm) below the Ultra-Lock to disengage the auto lock mechanism when the shade is raised.

7 CONTROLLERS AND CHANNELS

7.1 Using P2 Button on existing controller to add a new controller or channel

A = Existing controller or channel (to keep)

B = Controller or channel to add or remove

Press **P2** on controller **A**.

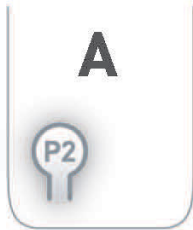

Press **P2** on controller **A**.

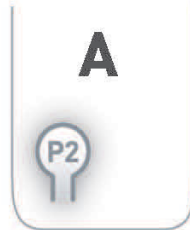

Press **STOP** on a new controller to add it.



Motor Response



Motor Response



Motor Response



IMPORTANT Consult user manual for your controller or sensor

7.2 Using a pre-existing controller to add or delete a controller or channel

A = Existing controller or channel (to keep)

B = Controller or channel to add or remove

Press **P2** on controller **A**.

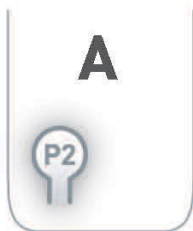

Press **P2** on controller **A**.

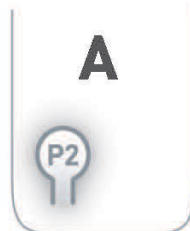

Press **P2** on the controller **B** to remove it.



Motor Response



Motor Response



Motor Response



IMPORTANT Consult user manual for your controller or sensor

8 FAVORITE POSITIONING

8.1 Set a favorite position

Move shade to the desired position by pressing the **UP** or **DOWN** button on the controller.

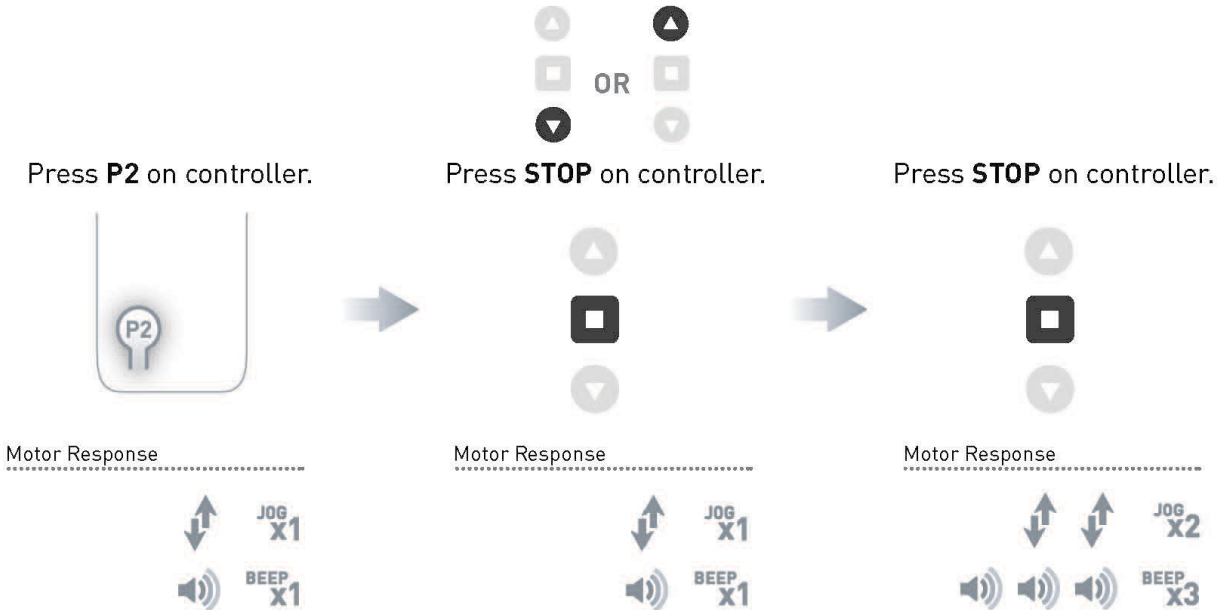

8.2 Send shade to favorite position

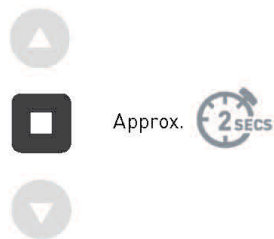

8.3 Delete favorite position

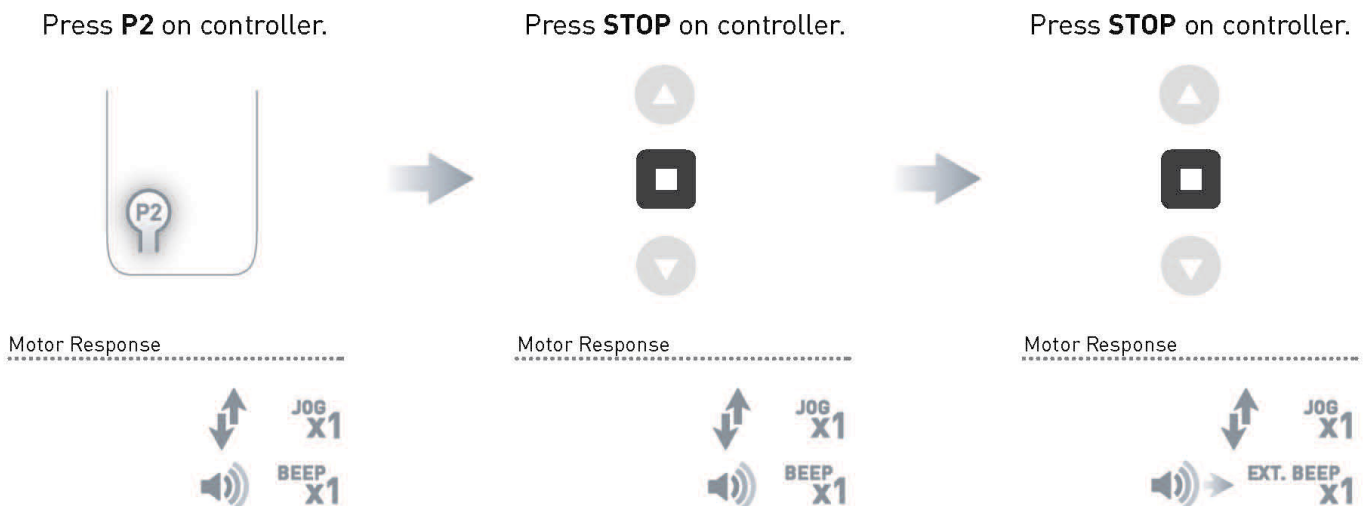

9 TILT & ROLLER MODE

9.1 Toggle motor to Tilt Mode

Default motor mode is Roller after initial Limits have been set, use following steps to change to Roller Mode.

Hold **UP & DOWN** on controller.

Press **STOP** on controller.



Motor Response



Motor Response



9.2 Toggle Motor to Roller Mode

If motor is in Tilt Mode, use following steps to change to Roller Mode.

Hold **UP & DOWN** on controller.

Press **STOP** on controller.



Motor Response



Motor Response



10 ADJUSTING SPEED

10.1 Increase Motor Speed

Default motor mode is the slowest speed.

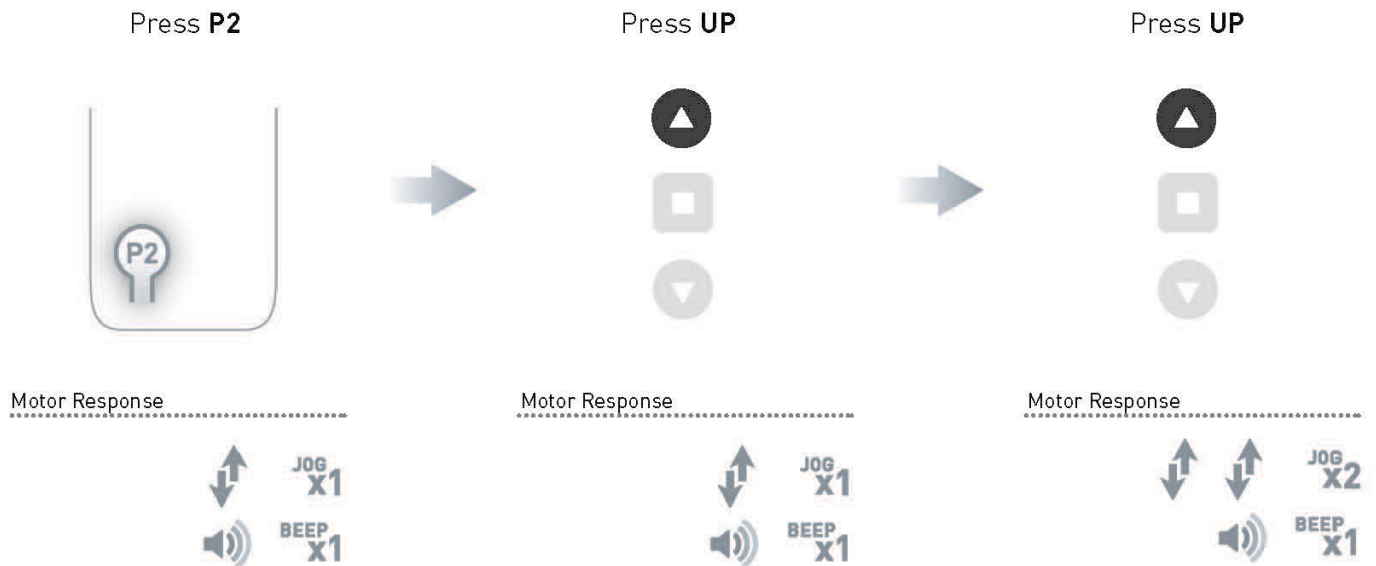

10.2 Decrease Motor Speed

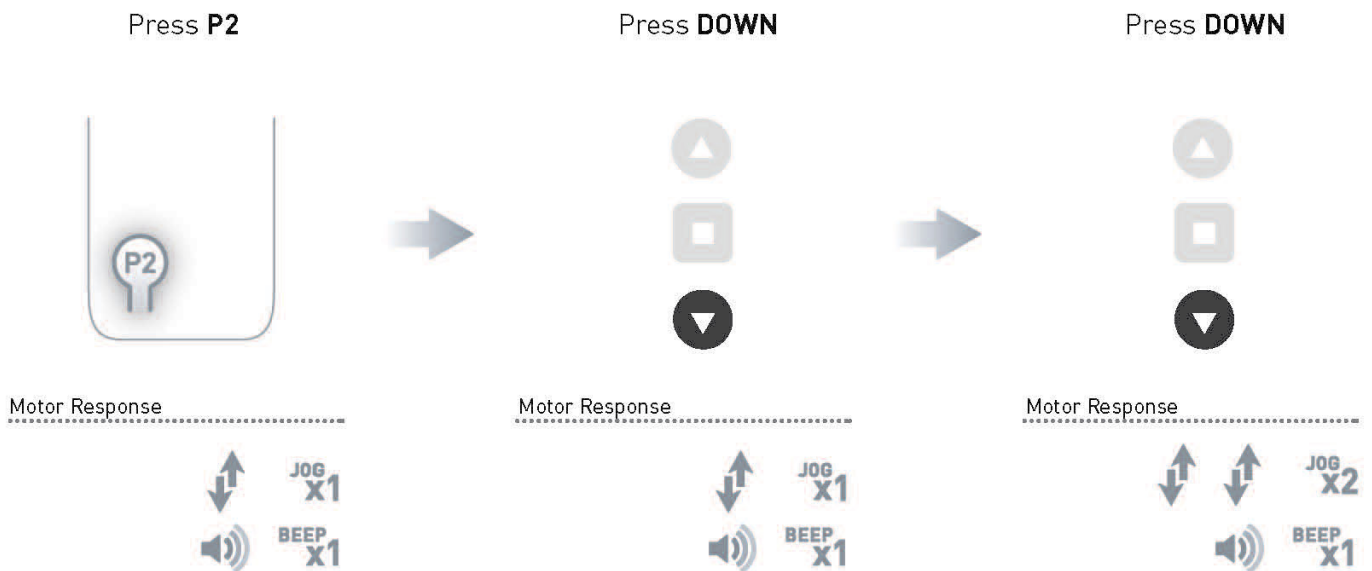

11 SOFT STOP CONFIGURATION

11.1 Turn Soft Stop OFF

Motor must be in slowest speed to turn Soft Stop OFF.

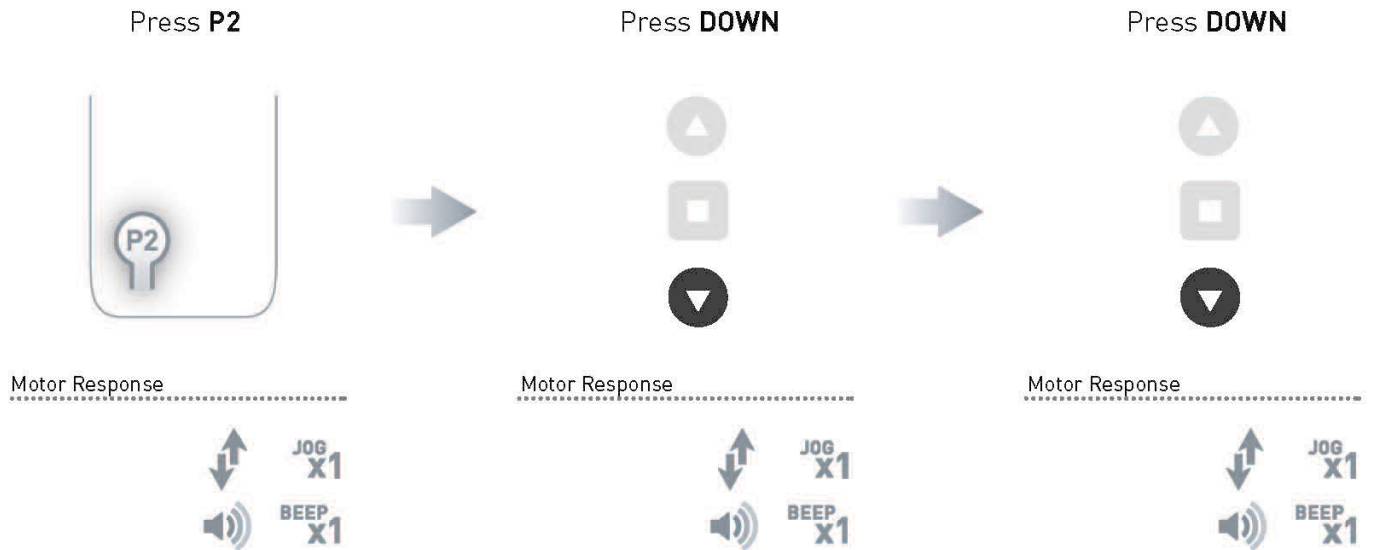

11.2 Turn Soft Stop ON

Motor must be in fastest speed to turn Soft Stop ON.

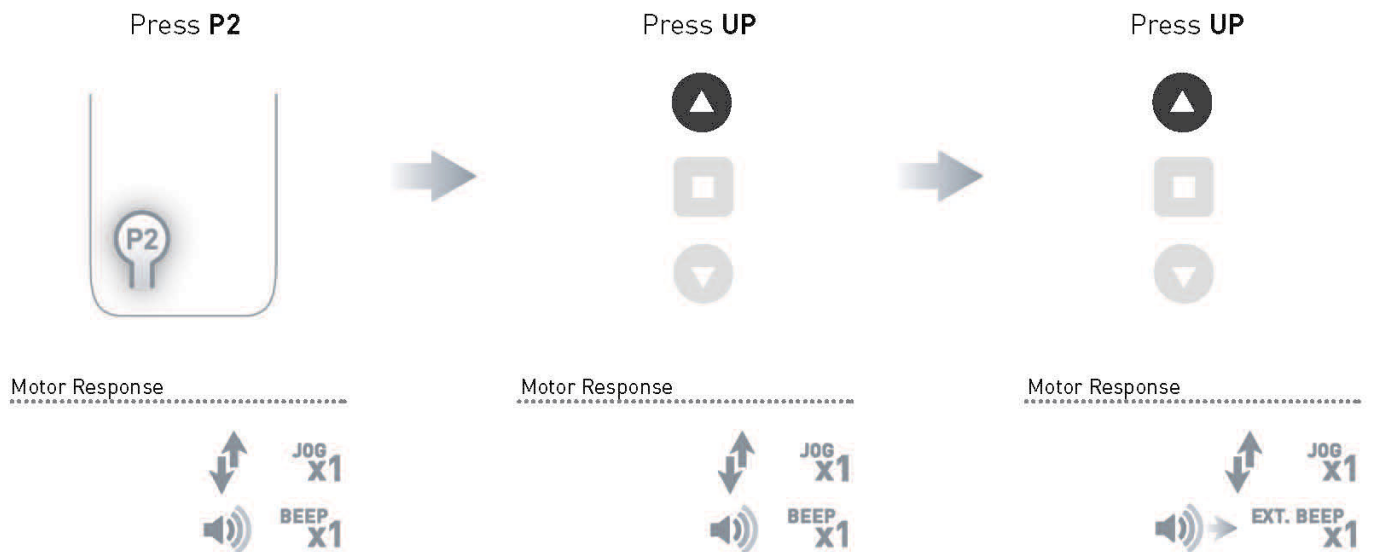

12 BATTERY CHECK FUNCTION

12.1 Send Shade to battery charge level

Shade must be at Upper Limit.

Hold **UP**

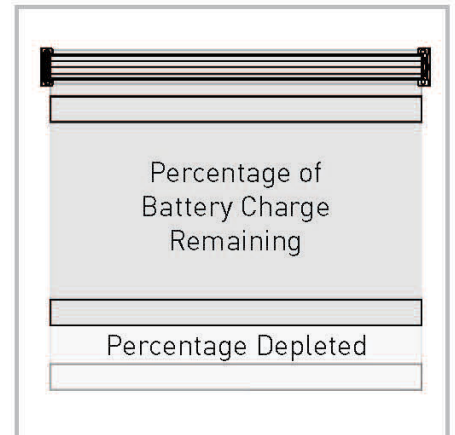
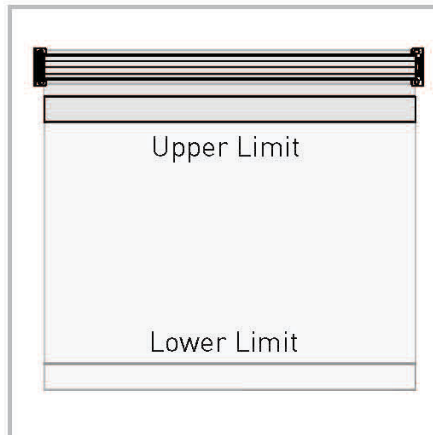

Motor Response

Approx. 

Shade must be at Upper Limit
Hold **UP** for Approx. 5s

Shade moves to percentage of
battery charge remaining

13 CHARGING LED

13.1 Turn Charging LED ON/OFF

Motor must be at Lower Limit.

Hold **DOWN** to toggle off



Motor Response

Approx.  Red LED flashes x3

Hold **DOWN** to toggle on



Motor Response

Approx.  Red LED flashes x3

14 SLEEP MODE

If multiple motors are grouped on a single channel, Sleep Mode may be used to put all but 1 motor to sleep, allowing programming of just the one motor that remains “Awake”. See page 6 for detailed **P1** functions.

Enter Sleep Mode

Sleep mode is utilized to prevent a motor from incorrect configuration during other motor setup.

Hold **P1** button on the motor head

Exit Sleep Mode: Method 1

Exit sleep mode once the shade is ready.

Press and release **P1** button on the motor head

Exit Sleep Mode: Method 2

Remove power and then re-power the motor.

Motor Response



Motor Response



15 TROUBLE SHOOTING

automateshades.com

Problem	Cause	Remedy
Motor is not responding	Battery in motor is depleted	Recharge with a compatible charger
	Insufficient charging from solar PV panel	Check connection and orientation of PV panel
	Transmitter battery is discharged	Replace battery
	Battery is inserted incorrectly into transmitter	Check battery polarity
	Radio interference/shielding	Ensure transmitter is positioned away from metal objects and the aerial on motor or receiver is kept straight and away from metal
	Receiver distance is too far from transmitter	Move transmitter to a closer position
	Charging failure	Check power supply to motor is connected and active
Motor beeps x10 when in use	Battery voltage is low	Recharge with a compatible charger
Cannot program a single motor (multiple motors respond)	Multiple motors are paired to the same channel	Always reserve an individual channel for programming functions. Use Sleep Mode to program individual motors.

Any Questions?

Contact our R-TEC Automation® in-house experts at 866.985.3423. Email us at RTECAutomation@RowleyCompany.com. Please use the [Custom Solutions Form](#) when ordering a Custom Solution.