

Pinable Worktable Underlayment

Rowley Company has used the best packaging techniques available while avoiding extra shipping costs.

Occasionally minor damage may occur on edges and corners of the product. We suggest positioning any blemished edges to the outside edge of your worktable.

1. Below are some typical table sizes. Choose the approximate size of your worktable. If your table is a different size, these instructions will still be helpful.
2. Place the Pinable Worktable Underlayment (stk#TC24/5 or TC24/8) sections on your worktable surface in the configuration as shown with the primed side up.
3. To cut off excess along worktable edges use a straight edge and a utility knife. Score the material with the utility knife until the Underlayment is cut more than half way through, then bend to break.

4. It is not necessary to secure the pinable worktable underlayment to the table.
5. We suggest unrolling sheets of aluminum foil (1/2" overlap) over the underlayment to prevent warpage due to long term exposure to heat and/or steam.
6. Cover the Underlayment with Table Padding (stk# TC10) up to the table edge.
7. Cover the Table Padding (stk# TC10) with enough Worktable Canvas (stk# TC60,stk# TC72, stk# TC96) to wrap over edges and under the table. Secure the upholstery canvas by stapling to the underside of the worktable. Table-Top Edge (stk# FC50) with 3/4" Self Adhesive Worktable Tape (stk#TR20) will be helpful if you plan to use a "T"-Square on fabric.

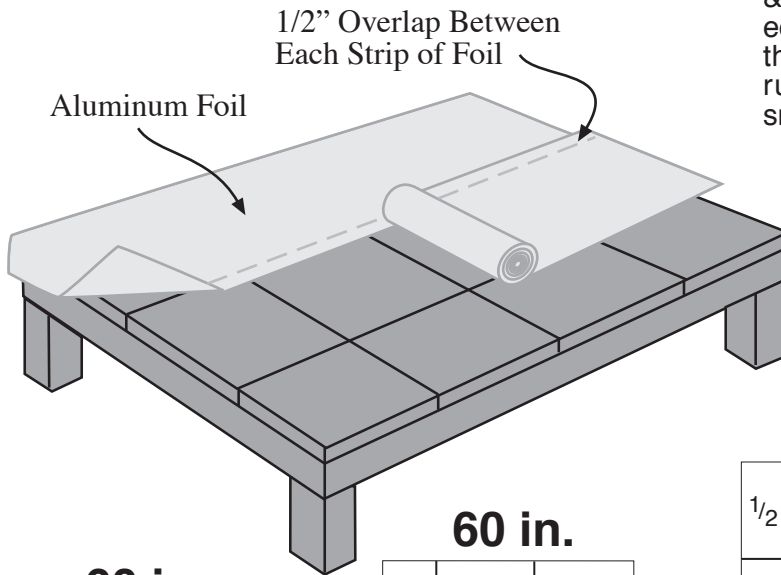

Trim Edges With Utility Knife & Straight Edge. Place ruff edges along the outer edge of the worktable. Do not place ruff cut edges along side smooth cut edges.

© ROWLEY CO. 1999

