

Headboard Cleat Instructions

The Headboard Cleat is used to mount a hanging headboard on the wall. The cleat plate on the wall has holes spaced 16" apart for mounting to wall studs. The 18" width allows for easy horizontal adjustment for the headboard. The projection is 7/16" so a 1/2" spacer (BB15) is used at the bottom for balance (see figure 1).

Step 1 Determine the height of the bottom of the headboard (see figure 1). Mark this measurement on the wall. A cleat plate should be mounted on the wall at least 3/4's of the way up the back of the headboard. Find 2 studs and mount the cleat near where the center of the headboard will be.

Step 2 From the mark on the wall indicating the bottom of the headboard measure to the bottom of the cleat plate just mounted. Add 3 1/2" to that to determine the mounting position of the cleat plate that goes on the back of the headboard \oplus in figure 1. Figure 2 shows the Headboard Cleat is 3 1/2" when together.

Step 3 On the back of the headboard measure from the bottom to the determined \oplus height of the cleat plate and make a mark. Repeat this marking about 10 to 15 inches apart centering on the headboard as close as possible with the cleat plate on the wall. For King size headboards 2 Headboard Cleats should be used.

Step 4 To secure the headboard use a 1 1/2" angle iron (AG15) on the stud closest to each end at the bottom of the headboard. This will prevent it from being moved (see figure 3).

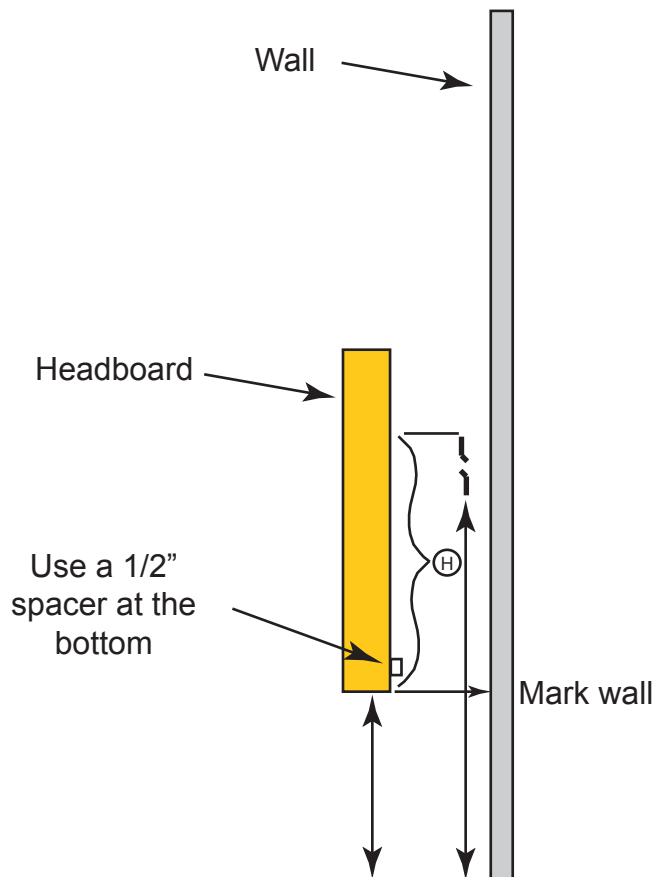

Figure 1

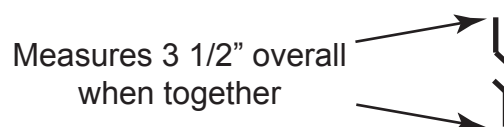

Figure 2

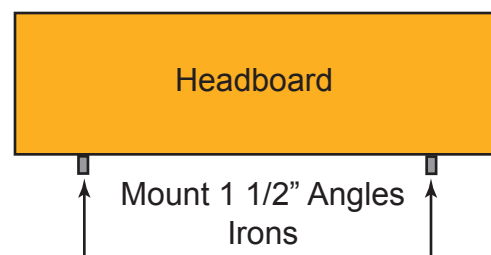

Figure 3