

# FINESTRA<sup>®</sup> CUSTOM R-TEC AUTOMATION<sup>®</sup> CENTER OR ONE-WAY DRAW TRAVERSE SYSTEMS INSTALLATION INSTRUCTIONS

Please read all instructions before starting

## INTRODUCTION:

The Finestra<sup>®</sup> Custom R-TEC Automation<sup>®</sup> Traverse System is used to electronically control the drapery using a Slim Drapery Motor and Remote Control. By using a Remote Control or the R-TEC Automation<sup>®</sup> App via a smartphone or tablet, the operator can open and close the drapery smoothly and precisely.

The maximum fascia width for this system is 16' continuous and 36' spliced. The maximum track width for this system is 19' continuous and 36' spliced. The maximum drapery weight is 110 lbs.

## How to get started using your Finestra<sup>®</sup> Custom R-TEC Automation<sup>®</sup> Heavy Duty Traverse System:

- Please read all the instructions provided with your Slim Drapery Motor.
- Your motor will be shipped in "sleep mode" and must be woken up before using.
- You will need a remote control or a smartphone to set up and control your Slim Drapery Motor.
- Only use power options for your motor that are available through Rowley Company.

## PARTS LIST:

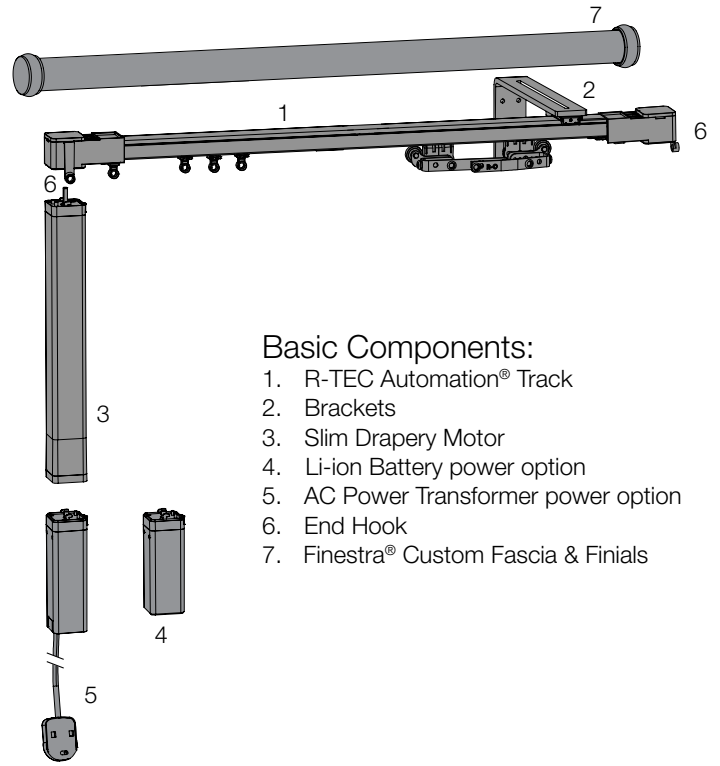

### Basic Components:

1. R-TEC Automation<sup>®</sup> Track
2. Brackets
3. Slim Drapery Motor
4. Li-ion Battery power option
5. AC Power Transformer power option
6. End Hook
7. Finestra<sup>®</sup> Custom Fascia & Finials

## BRACKET PLACEMENT:

It's recommended to use 1 bracket beside each pulley. On the remaining part of the R-TEC Automation<sup>®</sup> Track, bracket-to-bracket distances should be no more than 24". Also, 1 bracket should be placed on each side of a splice if used.

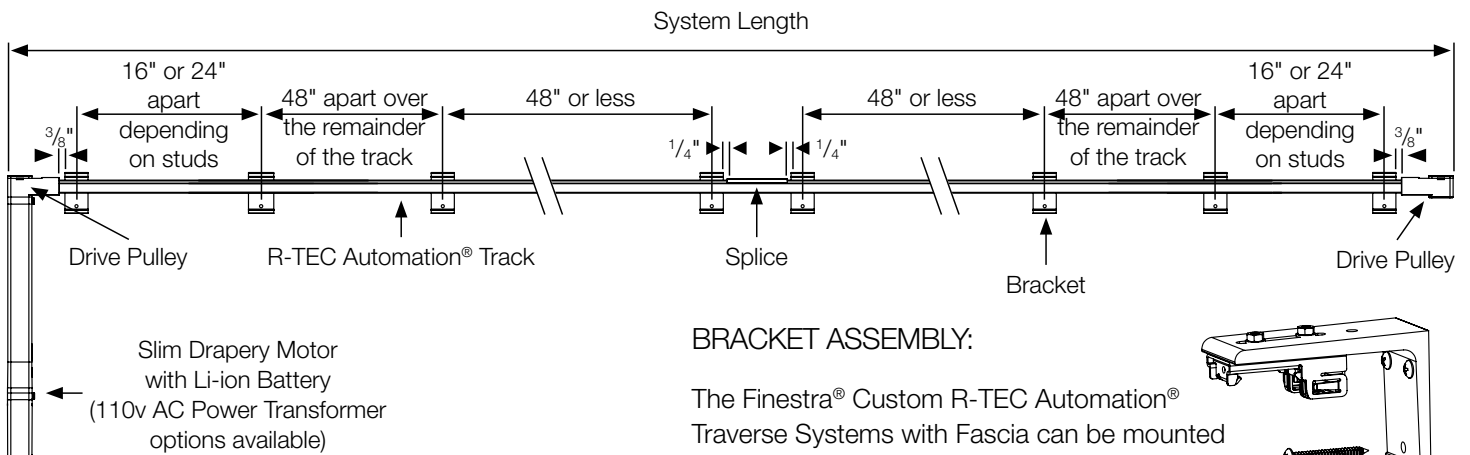

## BRACKET ASSEMBLY:

The Finestra<sup>®</sup> Custom R-TEC Automation<sup>®</sup> Traverse Systems with Fascia can be mounted on the wall only; no ceiling mount.

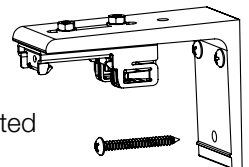

**WALL MOUNT TRACK SYSTEM INSTALL:**

NOTE: Installer is responsible for determining the correct mounting fastener and wall location per the wall construction type.

Step 1. Locate brackets.

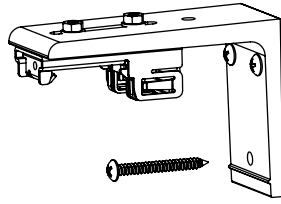

Step 2. Mount brackets to wall.

Step 3. Install system at an angle.

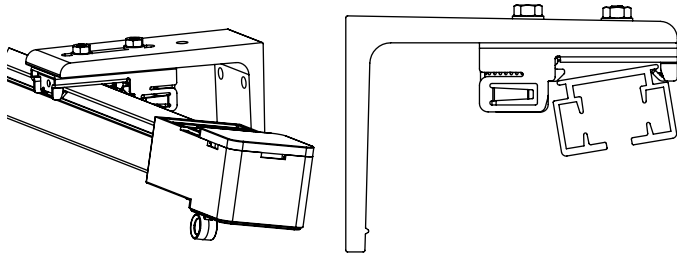

Step 4. Push system upward until system clicks in place.

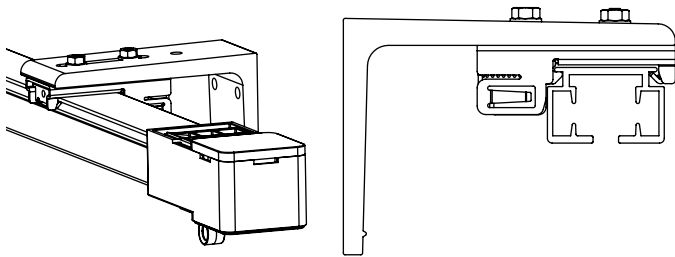

NOTE: To release track, push release lever.

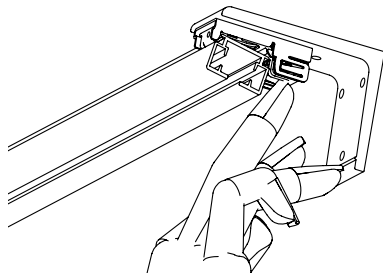

Step 5. Install End Hook on both Drive Pulleys.

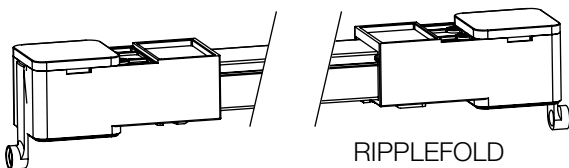
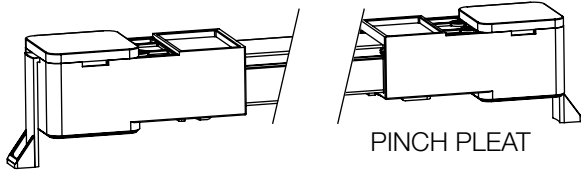

NOTE: Carriers can be added or removed with the Drive Pulley installed.

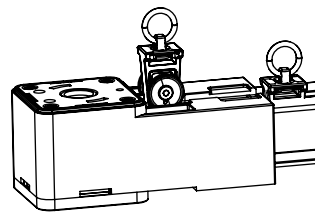

PINCH PLEAT

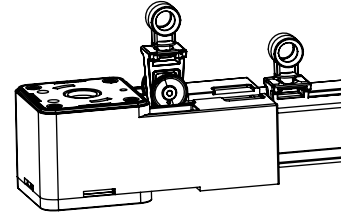

RIPPLEFOLD

Step 6. Install the End Stops.

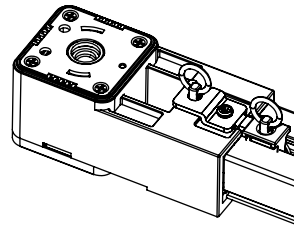

PINCH PLEAT

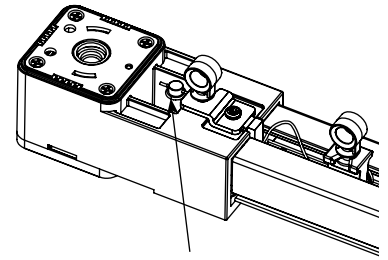

RIPPLEFOLD: Place the cord & attachment tab under the End Stop and tighten the fastener.

Step 7. Install the Fascia on the Track. Angle fascia clips over the Track, then push the Fascia and Fascia Clips down until they click into place.

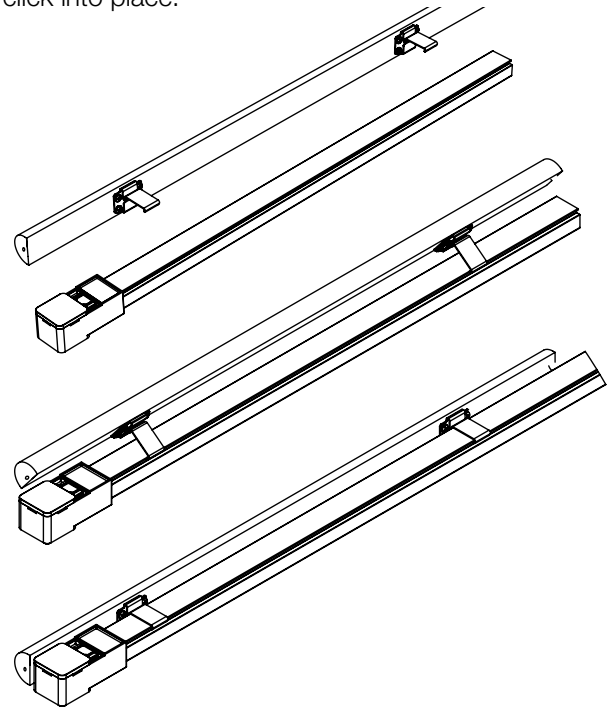

Step 8. Install the Finials or End Caps by screwing them into the Fascia on both ends.

