

R-TRAC MANUAL 4001 CORD DRAW TRACK SYSTEMS

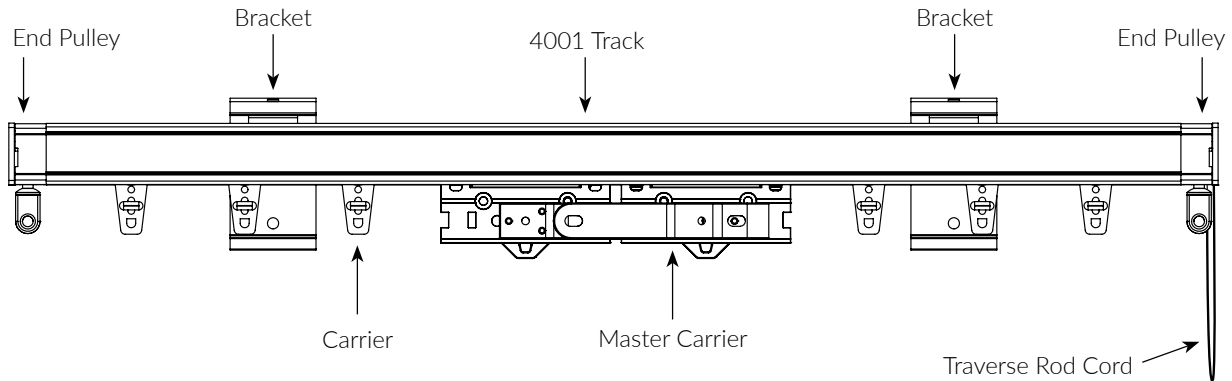

Easily upgrade your Track System with Finestra® Wood Hardware!

• Fascia included if ordering Finestra® Wood Traverse System. Finials sold separately.



1 – CHOOSE YOUR SYSTEM QUANTITY & LENGTH

Let our in-house experts know how many systems to assemble, custom cut to your exact specification. Minimum 18". Lengths up to 16' continuous and 32' spliced.

2 – CHOOSE YOUR TRACK INFORMATION

Select from Ceiling or Wall Mount. If ordering Double Track, complete Back Track information if different from Front Track.

3 – CHOOSE YOUR TRACK COLOR

Select from White or Bronze. Components will match Track Color unless otherwise noted.

4 – CHOOSE YOUR DRAW, DRAPERY STYLE & MASTER CARRIER

Select from One-Way Right or Left, Center or Stationary; Pinch Pleat or Ripplefold; Overlap Master Carriers are standard, or Butt Master Carrier option can be substituted if Ripplefold Drapery Style is selected.

PINCH PLEAT

- Carriers available in White or Bronze. Please specify number of carriers.



RIPPLEFOLD

- Friction Carriers available in White. Roller Carriers available in White or Bronze. 100% fullness only.
- Butt Master Carriers available, allowing some light to filter between draperies on center draw treatments.



5 – CHOOSE YOUR CORD DETAILS

Insert your Cord Drop Length in inches. Cord is White.

R-TRAC MANUAL 4001 CORD DRAW TRACK SYSTEM

REV February 1, 2025

Ceiling or Wall Mount
Pinch Pleat or Ripplefold

ACCOUNT # _____

Company _____ Contact _____ Date _____
 Street Address _____ Person to contact with technical questions _____
 City _____ State _____ Zip _____ PO _____ Phone _____
 Email _____ (required for shipping confirmation)
 Ship to (if different from above) _____ Attn _____
 Street Address _____ City _____ State _____ Zip _____

PLEASE COMPLETE ITEMS 1 THROUGH 11.

For assistance, call Customer Service at 800.343.4542 or 704.866.0650.
Email completed form to sales@rowleycompany.com.

1 Total number of systems to be made to these specifications. → (Use another order form for systems with different specifications)

2 FRONT TRACK INFORMATION Track/Bracket <input type="checkbox"/> WHITE Color: <input type="checkbox"/> BRONZE	LENGTH <input type="text"/> ft. <input type="text"/> in. Minimum 18" <input type="checkbox"/> CEILING MOUNT <input type="checkbox"/> WALL MOUNT	Components will match Track Color unless otherwise noted.
---	--	--

3 DRAW	<input type="checkbox"/> ONE-WAY LEFT <input type="checkbox"/> ONE-WAY RIGHT <input type="checkbox"/> CENTER DRAW <input type="checkbox"/> Right Cord <input type="checkbox"/> Left Cord <input type="checkbox"/> STATIONARY
--------	--

4 DRAPERY STYLE & MASTER CARRIER Color of <input type="checkbox"/> WHITE Carriers: <input type="checkbox"/> BRONZE	<input type="checkbox"/> PINCH PLEAT CP10 Carriers CSC1/ NUMBER OF PINCH PLEAT CARRIERS: _____	<input type="checkbox"/> RIPPLEFOLD (White Only) 100% Fullness - Friction Carriers CSC2/ <input type="checkbox"/> RIPPLEFOLD 100% Fullness - Roller Carriers CSC3/ <input type="checkbox"/> BUTT MASTER (Ripplefold only)
--	---	---

5 CORD COLOR: WHITE	CORD DROP LENGTH: _____"
---------------------	--------------------------

6 IS THIS BUILD A DOUBLE TRACK? Yes No *If yes, please complete items 7 through 11. If no, please skip to item 11.

7 BACK TRACK INFORMATION Track/Bracket <input type="checkbox"/> WHITE Color: <input type="checkbox"/> BRONZE	LENGTH <input type="text"/> ft. <input type="text"/> in.	Components will match Track Color unless otherwise noted. If ordering Double Track, then double the price listed in the price chart for your system.
--	--	---

8 DRAW	<input type="checkbox"/> ONE-WAY LEFT <input type="checkbox"/> ONE-WAY RIGHT <input type="checkbox"/> CENTER DRAW <input type="checkbox"/> Right Cord <input type="checkbox"/> Left Cord
--------	--

9 DRAPERY STYLE & MASTER CARRIER Color of <input type="checkbox"/> WHITE Carriers: <input type="checkbox"/> BRONZE	<input type="checkbox"/> PINCH PLEAT CP10 Carriers NUMBER OF PINCH PLEAT CARRIERS: _____	<input type="checkbox"/> RIPPLEFOLD (White Only) 100% Fullness - Friction Carriers <input type="checkbox"/> RIPPLEFOLD 100% Fullness - Roller Carriers <input type="checkbox"/> BUTT MASTER (Ripplefold only)
--	---	---

10 CORD Color: WHITE	CORD DROP LENGTH: _____"
-------------------------	--------------------------

11 READ THE TERMS OF SALE on the Custom Solutions Payment Form on page 3, sign and submit along with your signed forms.

SPECIAL INSTRUCTIONS

SHIPPING » [Flat Rate Shipping Program](#) Lengths over 8' will ship truck and incur an oversized fee. Splicing options for overlength sizes and alternative freight quotes available.

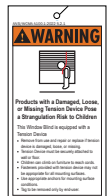

Rowley® Company
230 Meek Road / Gastonia / NC / 28056
Phone » toll-free 800-343-4542 or local 704-866-0650
© 2025 Rowley® Company, LLC

Signature of purchaser / cardholder

Date

DESIGN your WINDOW ▶



PAYMENT FORM

ACCOUNT # _____

To place a Custom Solutions Shade System or Drapery Hardware System order, you must complete and sign the Payment Form along with the applicable system build form. You may submit your completed forms via email to Sales@RowleyCompany.com.

For Order Forms, visit RowleyCompany.com/CustomSolutions

<input type="radio"/> OVERNIGHT SHIPPING (additional freight will apply)	SHIPPING » Flat Rate Shipping Program Lengths over 8' will ship truck and incur an oversized fee. Splicing options for overlength sizes and alternative freight quotes available.								
SELECT ONE <input type="radio"/> <input type="radio"/> <input type="radio"/> <input type="radio"/>	EXPIRATION DATE <table border="1" style="width: 100%; height: 20px; border-collapse: collapse;"> <tr> <td style="width: 25%;"></td> <td style="width: 25%;"></td> <td style="width: 25%;"></td> <td style="width: 25%;"></td> </tr> </table>								
CREDIT CARD # - LAST 4 DIGITS <table border="1" style="width: 100%; height: 20px; border-collapse: collapse;"> <tr> <td style="width: 25%;"></td> <td style="width: 25%;"></td> <td style="width: 25%;"></td> <td style="width: 25%;"></td> </tr> </table>					SECURITY CODE <table border="1" style="width: 100%; height: 20px; border-collapse: collapse;"> <tr> <td style="width: 25%;"></td> <td style="width: 25%;"></td> <td style="width: 25%;"></td> <td style="width: 25%;"></td> </tr> </table>				
I authorize Rowley® Company to charge the credit card above for all of my orders submitted to Rowley® Company. I have read, understood and agree to the Terms of Sale on this payment form.									
<table border="1" style="width: 100%; border-collapse: collapse;"> <tr> <td style="text-align: center; padding: 5px;"> Credit Card Billing Address (if different than ship to address) </td> </tr> <tr> <td style="padding: 5px;"> Complete Name of Card Holder _____ </td> </tr> <tr> <td style="padding: 5px;"> Street Address _____ </td> </tr> <tr> <td style="padding: 5px;"> City _____ State _____ Zip _____ </td> </tr> <tr> <td style="padding: 5px;"> Phone _____ </td> </tr> <tr> <td style="padding: 5px;"> Email _____ </td> </tr> </table>	Credit Card Billing Address (if different than ship to address)	Complete Name of Card Holder _____	Street Address _____	City _____ State _____ Zip _____	Phone _____	Email _____	<table border="1" style="width: 100%; border-collapse: collapse;"> <tr> <td style="width: 40px; height: 20px; border: 1px solid black;"></td> <td style="padding: 5px;"> Ship and apply to my pre-approved Net 30 account. Account # _____ </td> </tr> </table> <p style="font-size: small; margin-top: 10px;"> The price of the custom build includes all parts, labor and packaging, but does not include sales tax where applicable or shipping charges, for which the receiver is responsible. All orders will ship within five business days from confirmation of order with satisfactory payment arrangements. Automated® Traverse orders will ship within 10 - 15 business days. For commercial orders, request a quote with timeline. Terms: Net 30 days to pre-approved accounts only or credit card. Prices, design and availability are subject to change or withdrawal without notice. </p>		Ship and apply to my pre-approved Net 30 account. Account # _____
Credit Card Billing Address (if different than ship to address)									
Complete Name of Card Holder _____									
Street Address _____									
City _____ State _____ Zip _____									
Phone _____									
Email _____									
	Ship and apply to my pre-approved Net 30 account. Account # _____								
_____ Signature of purchaser / cardholder	_____ Date								

TERMS OF SALE WARRANTIES BY ROWLEY® COMPANY

Rowley® Company agrees to repair or replace, free of charge, any Custom Solutions Shade or Track System that due to faulty parts or workmanship in the assembled Shade or Track System is returned freight pre-paid to Rowley® Company within ninety (90) days of delivery. The parts in the system are covered by a ten year warranty. These warranties do not cover systems that have been subjected to abuse. The Slim Drapery Motor is covered by a 5 year warranty.

Orders for Custom Solutions Shade or Track Systems are not cancelable and cannot be altered. Custom Solutions Shade or Track Systems are not returnable for any reason except warranty repair, as described above. The buyer verifies that all sizes and other specifications are correct. A Custom Solutions Shade or Track System will be custom-built to the size and other specifications written on the system order form. Rowley® Company will repair or replace without charge any Custom Solutions Shade or Track System that is not made correctly to those specifications. **THE CUSTOMER WILL BE CHARGED FOR ANY REPAIRS OR REPLACEMENT NECESSITATED BY AN ERROR IN THE MEASUREMENT OR OTHER SPECIFICATIONS.**

OWNERSHIP: All selected shipping preferences are F.O.B. shipping point from any Rowley® location; the buyer owns the shipment as soon as it leaves the Rowley® Company loading dock. In the event of damaged shipment, the buyer must accept the shipment and place a claim with the carrier. Prices quoted include all parts, labor and packaging for all Custom Solutions Shade or Track Systems. The buyer is responsible for shipping costs.